



SAMPLING
SOLUTIONS

MEGA SYSTEM

CALIBRATION
& METROLOGY

ARTIK SERIES



- Efficient even at high temperatures
- High efficiency cooling system
- 18-litre tank
- Automatic thermoregulation
- High flow recirculation pump



CARE FOR THE
ENVIRONMENT



ARTIK SERIES

ARTIK LT

The ARTIK LT cooling system is a portable thermal container, which can be used to house accessories for condensation collection or for sampling collection, in cases where samples must be kept cool.

To cool accessories, the temperature may be lowered by filling the tank with cold water or by using dry ice and / or ice packs. This allows the unit to be used when there is no power supply and/or for short duration sampling.

The ARTIK LT cooling system comes complete with thermometer and support for absorbers / condensers.

ARTIK XP

The ARTIK XP model is a highly efficient cooling system that allows sampling when various types of accessories (e.g. condensation collectors, glass condensers, etc.) must be kept at constant, controlled temperatures.

The high-power capacity and excellent insulation of the tank walls in these cooling units guarantee efficient cooling and maintenance of liquid temperatures even when the ambient temperature is very high (35/40 °C).

A built-in digital thermostat regulates and controls the liquid temperature inside the large 18-liter tank.

Its compact shape and two side-handles allow for easy portability.

The ARTIK XP cooling system is equipped with a recirculation pump that allows the circulation of cold water from the tank to the prepared glass accessories (e.g. glass exchangers for sampling dioxins, etc.). The pump can be operated independently.

In the ARTIK XP cooling system, glass impingers or condensers can be housed with an optional dedicated support.



ACCESSORIES FOR CONDENSATION COLLECTION

ABSORBER FOR SILICA GEL

The absorber for silica gel containment is required to protect the sampler, particularly in emission sampling.

It is used in series, with the sampling line, before the air inlet to the sampler to detect and absorb humidity.

It is made of transparent plastic material so that the saturation state of the silica gel may be monitored, and it incorporates two sponge filters, which prevent the sampler from accidentally aspirating silica dust.

Capacity: approximately 0.8 kg silica gel.

GLASS CONDENSATION COLLECTORS

To determine the amount of water vapor present in the fumes, the sampled gas must be cooled and the condensation collected.

The glass condensation collector performs this function.

A glass tube is coiled around the bottle to make the collector more compact. This tube can be dismantled to facilitate emptying and washing.

The glass condensation collector can be cooled inside the ARTIK series cooling systems.

Capacity: approx. 0.45 l.

Outer diameter: 80 mm.



ARTIK SERIES

ARTIK LT

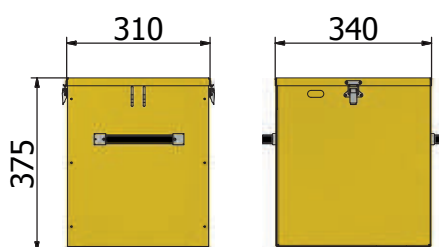

ARTIK XP

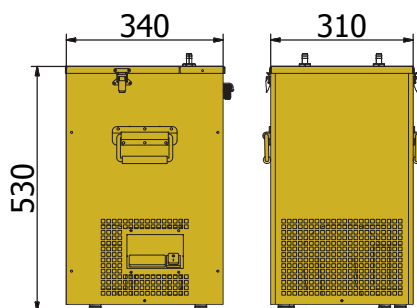

TECHNICAL SPECIFICATIONS

MODEL	ARTIK LT	ARTIK XP
■ Environmental Conditions		
Working Temperature Range	0 °C ÷ 45 °C - 95% UR	
■ Energy		
Power	-	230 Vac / 50 Hz
Consumption	-	390 w
■ Temperature Sensors		
Digital thermostat	-	✓
■ Features		
Cooling capacity	-	2586 BTU/h (652 kcal/h)
Water recirculating pump	-	✓
Recirculating hydraulic head	-	2 m
Thermostat	-	Digital
Thermometer	Removable	Built-in
Tank	18 L	
Dry weight	4,8 Kg	20 Kg
■ Supplied With		
Technical Manual	✓	
Impingers/condensators	✓	-

MEGA SYSTEM