



WASTE

SAMPLING
SOLUTIONS

MEGA SYSTEM

CALIBRATION
& METROLOGY

SPIRITUS



- Adiabatic Respirometer
- Compliant with UNI 11184:2016
- P.D.R.I. Potential Dynamic Respiration Index
- R.D.R.I. Real Dynamic Respiration Index
- OPTICAL sensor for oxygen measurement
- 10 L and 30 L reactor



CARE FOR THE
ENVIRONMENT



SPIRITUS

This continuous flow aerobic respirometer is dedicated to evaluating biomass biological stability by determining its Dynamic Respirometric Index (UNI 11184: 2016).

It is ideal for the routine analytical determination of biological stability on samples of solid, biostabilized, bio-dried and compost waste collected at all stages of the biostabilization process.

Biological stability is the degree of decomposition of easily biodegradable organic matter.

In an aerobic environment microorganisms use substrata organic substances as a source of nourishment, consuming oxygen and releasing carbon dioxide.

The SPIRITUS model determines two different dynamic respirometric indices:

- **P.D.R.I. - Potential Dynamic Respiration Index**
Sample biological stability value after main chemical-physical parameter normalization.
- **R.D.R.I. - Real Dynamic Respiration Index**
Sample biological stability value as is.

Dynamic respirometric tests measure the hourly oxygen consumption in biodegradable compounds contained in an organic matrix in condition of forced-air insufflation into the sample.

This provides the dynamic respiration index (DRI). This determination makes it possible to reproduce real-life conditions in the laboratory by assessing product biological stability based on their intended use.

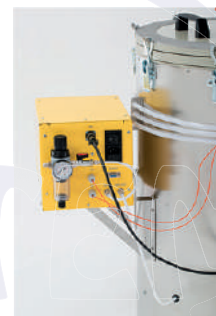

Optical sensor for reading oxygen in exhaust air.

The optical sensor, which detects oxygen, has numerous advantages and clearly differentiates itself from the polarographic sensor and the electrochemical sensor based on the following characteristics:

READING: the OPTICAL sensor does not require polarization time. While the polarographic sensor requires at least 24 hours of stabilization to detect correctly, the OPTICAL sensor is ready immediately on powering-up.

MAINTENANCE: the "polarographic" sensor requires the placement and frequent replacement of liquid electrolytes (toxic) in the cell. The OPTICAL sensor, on the other hand, is "plug and play" and in the event of a drop in performance, maintenance can be managed well before the sensor becomes unusable.

ACCURACY AND DERIVATION: the OPTICAL sensor has greater accuracy and performance stability throughout the duration of the oxygen reading in comparison to electrochemical and polarographic sensors, which are very sensitive to signal drift.

TECHNICAL FEATURES

The SPIRITUS model respirometer consists of:

- An adiabatic reactor body with an airtight seal, inside which nests an inner reservoir of approximately 30 liters that holds the sample under analysis. The reactor structure obliges incoming air to pass through the sample completely before exiting the reactor, thus preventing any contact between incoming air and exhaust air. It's available also a 10 liters reactor version.
- Thermometric probes measure the air temperature of the air entering, inside and leaving the reactor.
- Optical sensor for reading oxygen in exhaust air.
- Automatic system for checking leaks in the reactor. The instrument is equipped with a vacuum sensor that allows automatic vacuum control.
- Aeration (ventilation) system equipped with an input flow regulator.
- Mass Flow Meter for control and regulation of the flow to be insufflated into the reactor.
- PC laptop complete with software for managing multiple reactors and acquiring data from the respirometer.

SOFTWARE FEATURES

- The software allows the instrument and all its functions to be controlled by a PC using a USB port connection. It's possible to connect more than one drive to the same computer to manage everything in one interface in a simple and effective way.

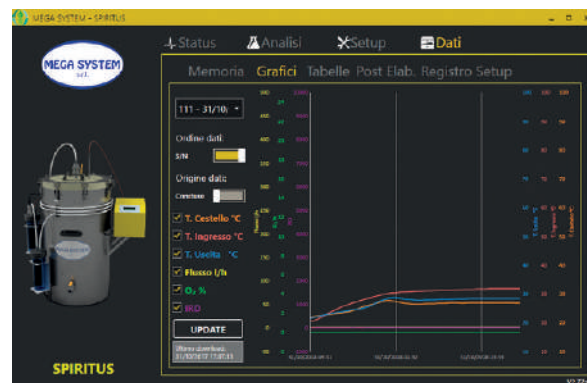
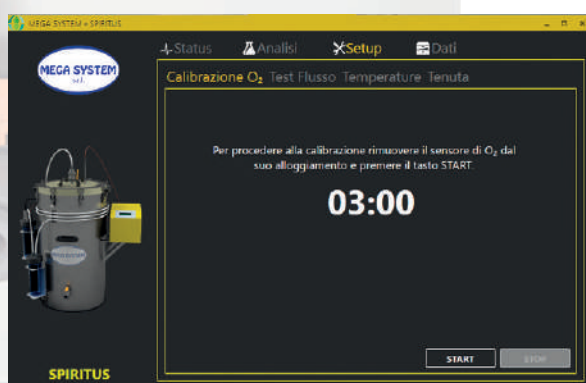

30 L REACTOR

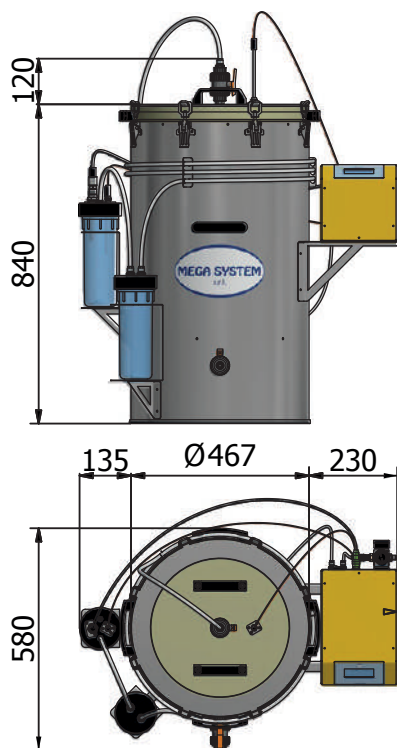

10 L REACTOR

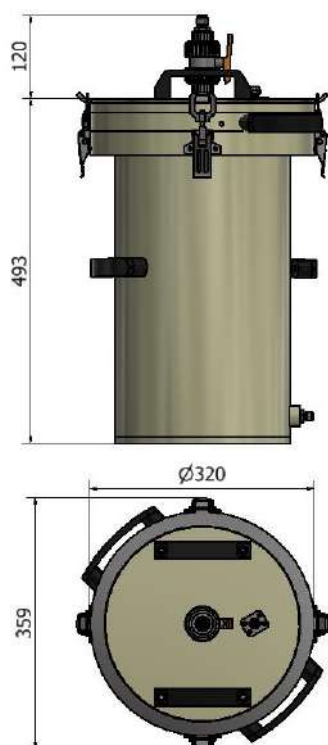

TECHNICAL SPECIFICATIONS

Operating Features

Working Temperature Range	0 ÷ +50 °C
Operative humidity	0 ÷ 95% UR
Input pressure	2,5 bar
Line Pressure	3 ÷ 15 bar

Electrical Features

Power	230 ± 10 Vac / 50 - 60 Hz
Consumption	15 W

Physical features

Nominal reservoir vol.	10 l	30 l
Weight	13,5 kg	45,6 kg

Interface, Data Archiving

Display	Alphanumeric LCD (20x4)
Interface	RS232 connection to PC

Flow performance

Range	10 ÷ 500 l/h
Resolution	0,1 l/h
Accuracy	± 1% set point – with flow > 175 l/h ± 1,75 l/h – with flow < 175 l/h

Options

Laptop PC

Supplied With

Technical Manual
Test report

Sensors

	Type	Range	Resolution	Accuracy
Input temperature	PT1000	0 ÷ +100 °C	0,1 °C	± 0,5 °C
Reactor temperature	PT1000	0 ÷ +100 °C	0,1 °C	± 0,5 °C
Gas output temperature	PT1000	0 ÷ +100 °C	0,1 °C	± 0,5 °C
Reactor pressure (leak test)	Digital	0 ÷ 1 bar	0,02 bar	± 0,05 bar
Oxygen	Optical	0 ÷ 25% vol	0,01% vol	± 0,2% vol

